

VKSD Disc Brake Caliper - Spring Applied, Hydraulically Released

See Publication Ref. No.M1030 Installation, Operation and Maintenance.

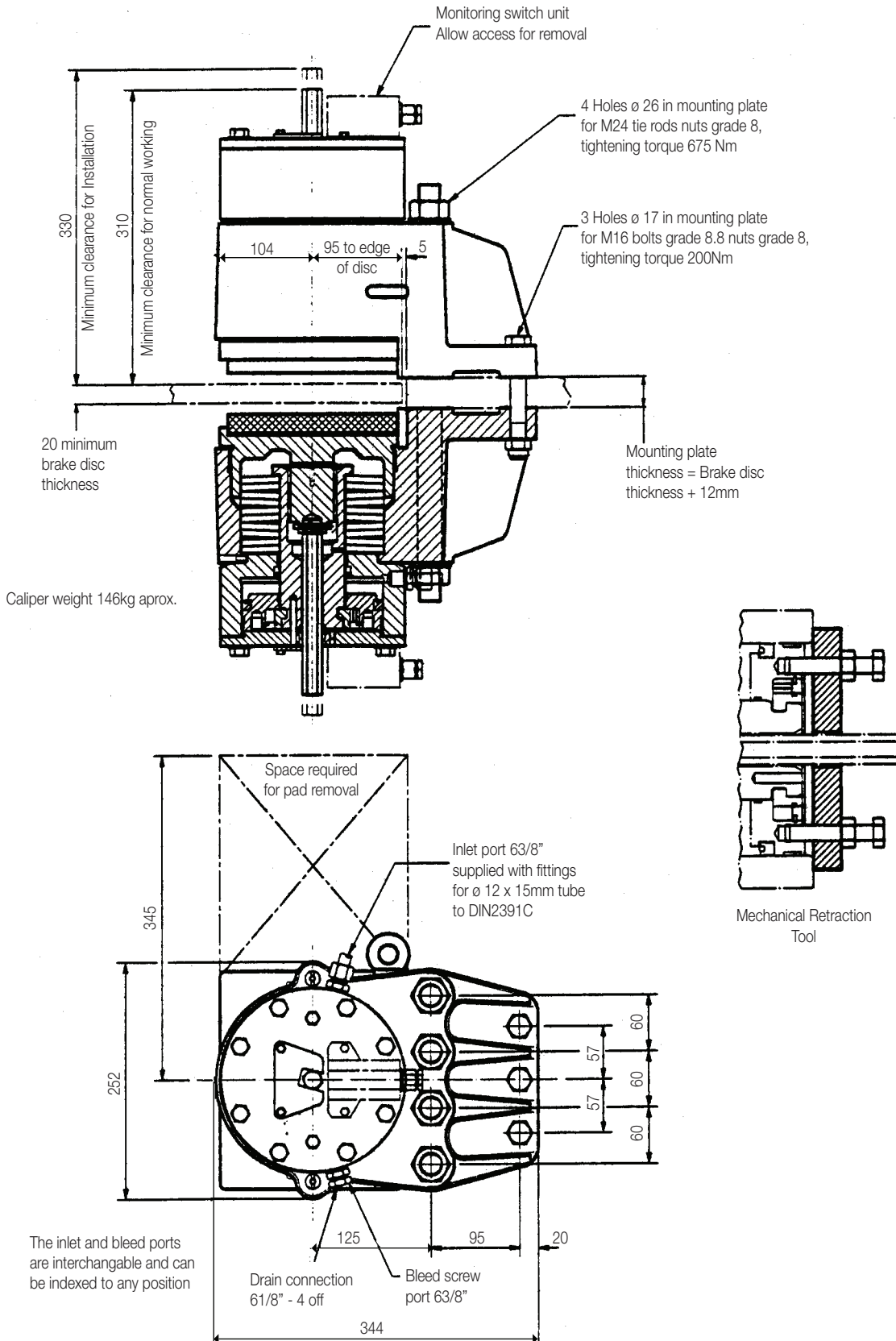

# VKSD Disc Brake Caliper - Spring Applied, Hydraulically Released

## Technical Data:

### BRAKE DISC

Diameter - 1000mm minimum. There is no maximum limit except for practical considerations  
 Thickness - 20mm minimum. There is no maximum limit except for practical considerations  
 Material - standard discs sg iron to BS 2789 grade 420/1 2. (Twiflex data sheet DB 5002)  
 Finish - brake path surface to be 2µm or better.

### BRAKE PADS

Length	Width	Thickness	Area(2 pads)	Wear Allowance
208mm	180mm	22mm	748.8cm <sup>2</sup>	10mm

### HYDRAUICS

The recommended fluid is mineral oil based hydraulic fluid. Correctly formulated water-in-oil emulsions may also be used. Fluid displacement for 1 mm retraction at both pads - 28ml.

### BRAKE ADJUSTMENTS

The adjusting screw sets the air gap between brake pad and brake disc and allows brake pad wear to be taken up. In a high wear situation, re-setting should be frequent. See Installation, Operation and Maintenance Instructions for adjustment for pad wear. Monitoring units are optionally available to indicate a) brake off, b) wear adjustment required and c) pad replacement required.

### MECHANICAL RETRACTION

A mechanical retraction tool is supplied. and should only be used to release the brake in emergencies such as hydraulic supply failure. A failed seal would also necessitate the use of a mechanical retraction tool.

## Performance Data:

Caliper Type VKSD	Air Gap Setting mm	Braking Force kN	Pressure to Release Brake bar	Min. for full Retraction bar	Max Allowable Pressure bar	
High	2	119.0	124	138	163	Braking force assumes - a) a coefficient of friction between brake pad and brake disc of 0.4" b) a small loss due to spring pack friction c) an air gap setting as stated in the table Braking force is increased by reduction in air gap setting and vice versa.  Pressures stated allow for a small loss due to seal friction.  * This is only achieved by fully bedded-in and conditioned brake pads and a high standard of cleanliness and dryness at the friction surfaces. A bedding-in procedure is available in publication M1065. An appropriate service factor should be applied according to the duty. In the case of holding brakes or wet conditions this should be at least 2.
High	2	112.0	116	131	156	
High	2	104.0	108	124	149	
High	2	96.3	100	116	141	
High	2	88.2	92	108	133	
High	2	80.0	83	100	125	
High	2	71.2	75	92	117	
High	2	62.4	65	83	109	
Low	2	64.1	63	69	94	
Low	2	58.7	58	63	88	
Low	2	53.0	53	58	83	
Low	2	47.1	47	53	78	
Low	2	41.0	41	47	72	
Low	2	34.4	34	41	66	
Low	2	27.8	28	34	59	

### Braking Torque

Braking Torque (Tb) = Braking Force (Fb) x Effective Disc Radius (Re)  
 Effective Disc Radius (Re) = Actual Disc Radius (R) - 0.095m  
 For Tb in Nm. apply Fb in Newtons and R in metres  
 $Tb = Fb \times Re$  (Re = R - 0.095m)  
 $Tb = Fb (R - 0.095) \text{ Nm}$   
 For Tb in lbf ft. apply Fb in lbf and R in ft.  
 $Tb = Fb (R - 0.512\text{ft.}) \text{ lbf ft.}$

Twiflex disc brakes must be used with Twiflex asbestos free pads. The use of any other brake pad will invalidate the warranty. Twiflex Limited reserves the right to modify or change the design without prior notice. This document is the intellectual property of Twiflex Limited.



An Altra Industrial Motion Company

www.twiflex.com

9 Briar Road, Twickenham  
 Middlesex TW2 6RB - England  
 +44 (0) 20 8894 1161  
 Fax: +44 (0) 20 8755 5601



This approval is in Accordance with  
 Certificate number 850822  
 Issue 04 June 2009 © Twiflex 2001.

DS2202 11/11 Printed in USA